

CIRCULATORS FOR HEATING AND AIR CONDITIONING SYSTEMS



GENERAL DATA

Applications

Pump for hot water circulation in domestic central heating and air conditioning systems of the closed circuit pressurized type or open circuit type.

Construction features

Enbloc body composed of hydraulic section in cast iron and wet rotor motor. Motor casing in die cast aluminium. Impeller in technopolymer. Motor shaft in hardened stainless steel held in graphite bearings lubricated by the pumping medium.

Rotor protective jacket, stator jacket, and closing flange in stainless steel.

Ceramic thrust ring, ethylene-propylene seal rings and brass air breather plug. The two-pole asynchronous wet-rotor motor is resistance protected and does not require any form of overload protection.

Three-speed operation.

Protection rating: IP 44

Insulation class: F

Cable gland: PG 11

Installation: with horizontal motor shaft.

Standard voltage input: single-phase 230 V / 50 Hz

Special versions on request - alternative voltages and/or frequencies

- Designation index:
(example)

VA = circulator with threaded ports

VB = circulator with
DN 25 oval flanges

VD = twin circulator

maximum head (dm)

centre distance (mm)

standard (no ref.)

1/2"

X

32

= 1" 1/2 threaded ports

= 1" threaded ports

= 2" threaded ports

= DN32/PN6/10 flanged ports

VA 55 / 180 X

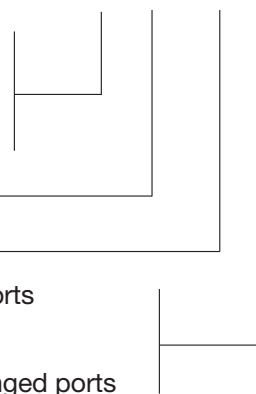

CIRCULATORS FOR HEATING AND AIR CONDITIONING SYSTEMS

TECHNICAL DATA

No.	PARTS	MATERIALS
1	PUMP BODY	CAST IRON
4	IMPELLER	TECHNOPOLYMER
7A	MOTOR SHAFT	STAINLESS STEEL
7B	ROTOR	—
8	STATOR	—
9	CAPACITOR	—
10	MOTOR CASING	DIE CAST ALUMINIUM
11	BREATHER PLUG	BRASS
100	TERMINAL BOX	—
127	SEAL RING	ETHYLENE POLYPROPYLENE
128	STATOR JACKET	STAINLESS STEEL
129	ROTOR JACKET	STAINLESS STEEL
130	CLOSING FLANGE	STAINLESS STEEL
131	THRUST RING SUPPORT	ETHYLENE PROPYLENE
132	BUSHINGS	GRAPHITE
133	THRUST RING	CERAMIC

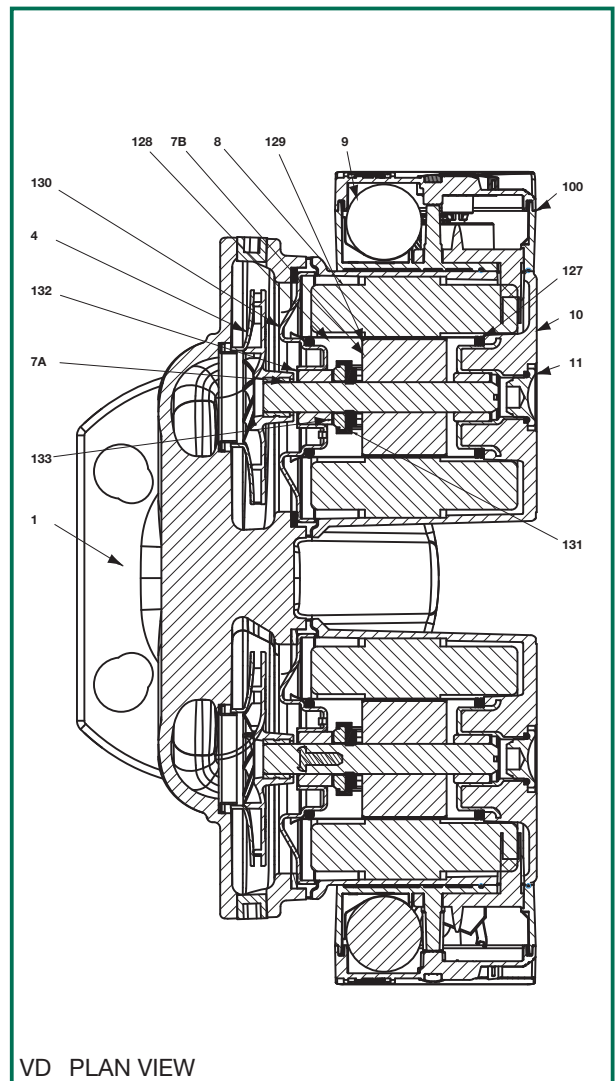
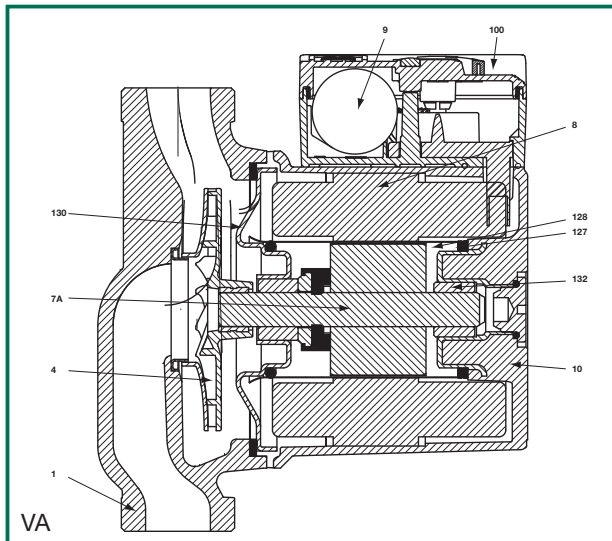

Operating range:

Liquid temperature range:

Liquid quality requirements:

Maximum working pressure:

Minimum suction pressure:

Installation:

SPECIAL executions on request:

Optional accessories:

VA - VB - VD: from 0.5 to 3.6 m³/h with head of up to 6 m.

VA - VB - VD: from -10°C to +110°C

clean, free of solids and mineral oils, non-viscous,
chemically neutral and approximating the properties of water
(max. glycol contents 30%).

VA - VB - VD 10 bar (1000 kPa)

the values are given in the relative tables.

with HORIZONTAL MOTOR SHAFT on discharge or return pipe,
with suction port as close as possible to expansion vessel, above
maximum boiler level and as far as possible from bends, elbows,
and circuit branches to avoid water turbulence with consequent
noise.

alternative voltages and/or frequencies

r³/₄"F - 1" F - 1¹/₄" F - 1¹/₄" M unions

DN20-DN25-DN32 oval counter-flanges

DN32/PN6 round counter-flanges

The performance curves are based on kinematic viscosity values = 1 mm²/s and density equivalent to 1000 kg/m³. Tolerance of curves to ISO 9906.

CIRCULATORS FOR HEATING AND AIR CONDITIONING SYSTEMS

Liquid temperature range: from -10°C to +110°C
 Maximum working pressure: 10 bar (1000 kPa)

VA 25/130 SINGLE WITH UNIONS

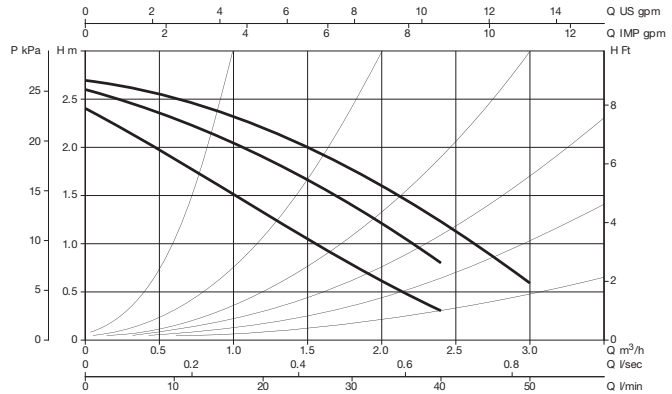
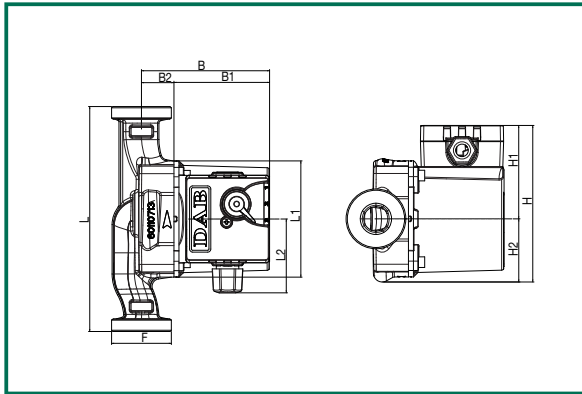
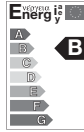

L	L1	L2	B	B1	B2	H	H1	H2	F	PACK DIMENSIONS			VOLUME m ³	WEIGHT Kg
										L	B	H		
130	93	59	102,5	76,5	26	125,5	75	50,5	48	135	135	150	0,0027	2,5

MODEL	POWER SUPPLY 50 Hz	CENTRE-DISTANCE mm	UNIONS ON REQUEST		ELECTRICAL DATA						MINIMUM SUCTION PRESSURE
			STANDARDIZED	SPECIAL	SPEED	rpm	P1 MAX W	In A	CAPACITOR µF Vc		
VA 25/130	1x230 V ~	130	1" F	3/4" F - 1 1/4" M	3	2655	43	0,19	1,5	450	t° +90°C m.c.a. 1,5
					2	2380	38	0,17			
					1	1680	31	0,15			

VA 25/180 SINGLE WITH UNIONS

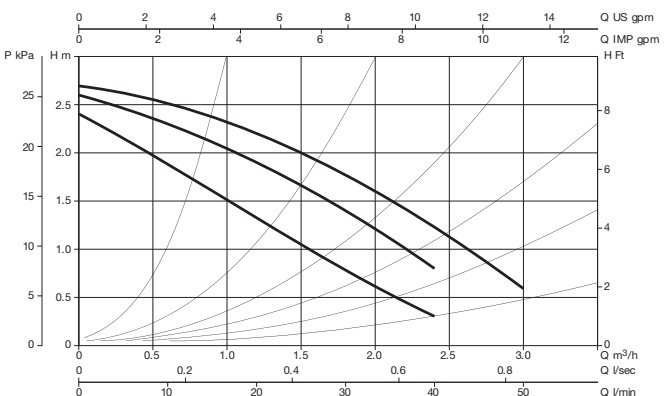
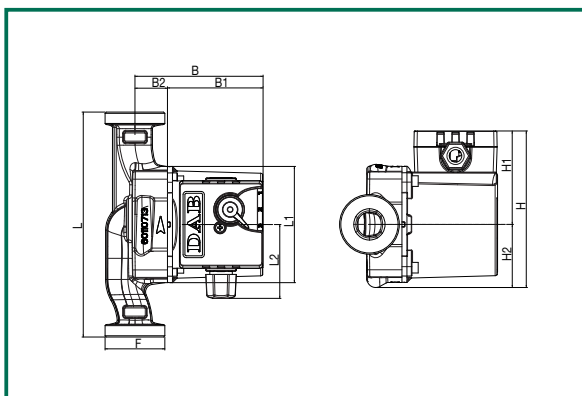
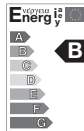

L	L1	L2	B	B1	B2	H	H1	H2	F	PACK DIMENSIONS			VOLUME m ³	WEIGHT Kg
										L	B	H		
180	93	59	102,5	76,5	26	125,5	75	50,5	48	130	190	150	0,0037	2,6

MODEL	POWER SUPPLY 50 Hz	CENTRE-DISTANCE mm	UNIONS ON REQUEST		ELECTRICAL DATA						MINIMUM SUCTION PRESSURE
			STANDARDIZED	SPECIAL	SPEED	rpm	P1 MAX W	In A	CAPACITOR µF Vc		
VA 25/180	1x230 V ~	180	1" F	3/4" F - 1 1/4" M	3	2655	43	0,19	1,5	450	t° +90°C m.c.a. 1,5
					2	2380	38	0,17			
					1	1680	31	0,15			

The performance curves are based on kinematic viscosity values = 1 mm²/s and density equivalent to 1000 kg/m³. Tolerance of curves to ISO 9906.

CIRCULATORS FOR HEATING AND AIR CONDITIONING SYSTEMS

Liquid temperature range: from -10°C to +110°C
 Maximum working pressure: 10 bar (1000 kPa)

VA 25/180X SINGLE WITH UNIONS

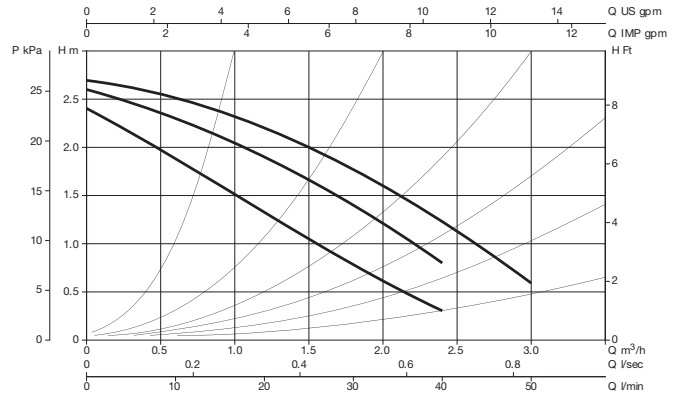
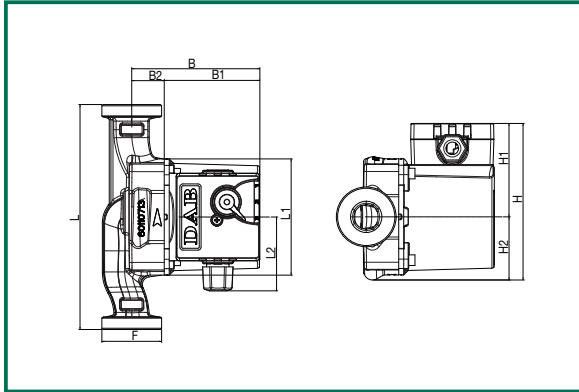
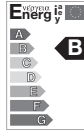

L	L1	L2	B	B1	B2	H	H1	H2	F	PACK DIMENSIONS			VOLUME	WEIGHT
										L	B	H	m ³	Kg
180	93	59	102,5	76,5	26	125,5	75	50,5	48	130	190	150	0,0037	2,6

MODEL	POWER SUPPLY 50 Hz	CENTRE-DISTANCE mm	UNIONS ON REQUEST		ELECTRICAL DATA						MINIMUM SUCTION PRESSURE	
					SPEED	rpm	P1 MAX W	In A	CAPACITOR			
										μF	Vc	
VA 25/180X	1x230 V ~	180	1" 1/4 F	3	2655	43	0,19	1,5	450	t° +90°C m.c.a. 1,5		
				2	2380	38	0,17					
				1	1680	31	0,15					

VA 35/130 SINGLE WITH UNIONS

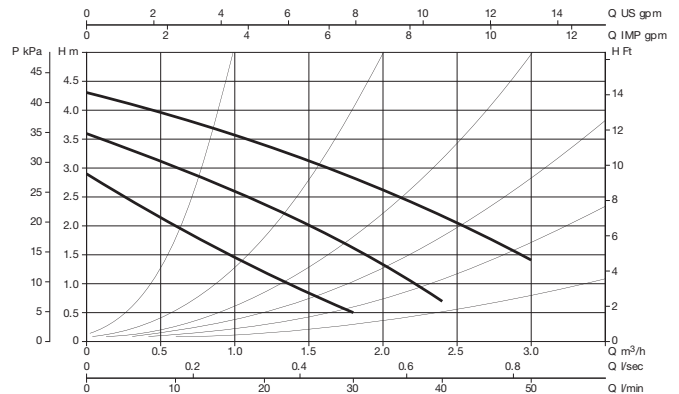
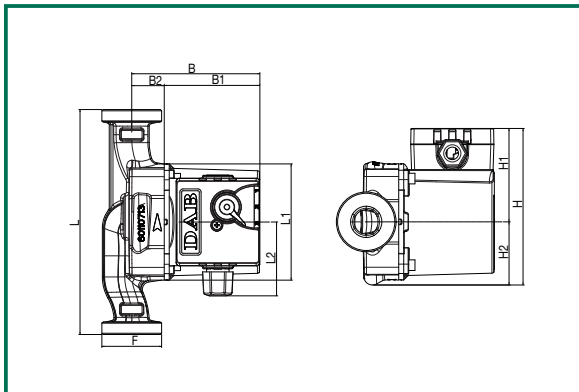
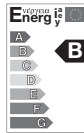

L	L1	L2	B	B1	B2	H	H1	H2	F	PACK DIMENSIONS			VOLUME	WEIGHT
										L	B	H	m ³	Kg
130	93	59	102,5	76,5	26	125,5	75	50,5	48	135	135	150	0,0027	2,5

MODEL	POWER SUPPLY 50 Hz	CENTRE-DISTANCE mm	UNIONS ON REQUEST		ELECTRICAL DATA						MINIMUM SUCTION PRESSURE	
			STANDARDIZED	SPECIAL	SPEED	rpm	P1 MAX W	In A	CAPACITOR			
										μF	Vc	
VA 35/130	1x230 V ~	130	1" F	3/4" F - 1 1/4" M	3	2465	56	0,25	1,7	450	t° +90°C m.c.a. 1,5	
					2	1930	50	0,22				
					1	1150	35	0,16				

The performance curves are based on kinematic viscosity values = 1 mm²/s and density equivalent to 1000 kg/m³. Tolerance of curves to ISO 9906.

CIRCULATORS FOR HEATING AND AIR CONDITIONING SYSTEMS

Liquid temperature range: from -10°C to +110°C
 Maximum working pressure: 10 bar (1000 kPa)

VA 35/130 - 1/2"

SINGLE WITH UNIONS

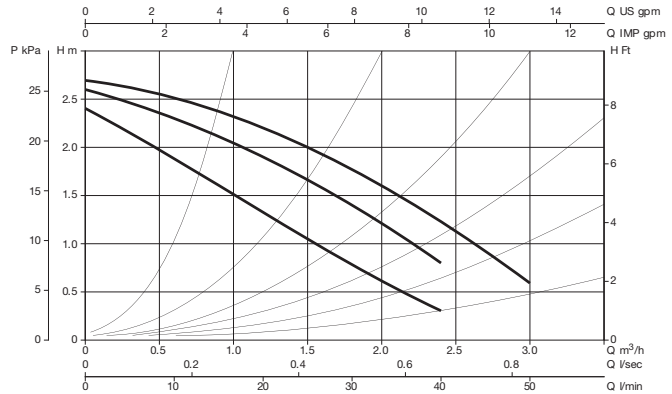
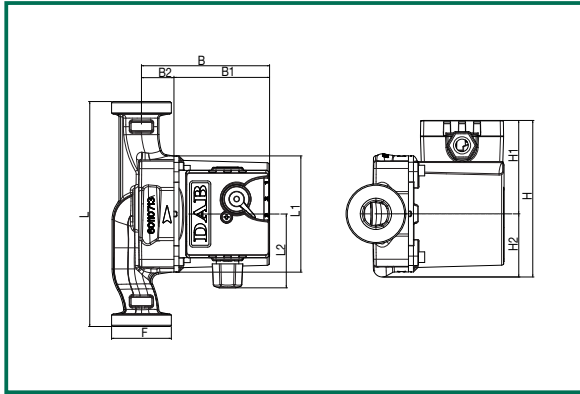
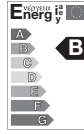

L	L1	L2	B	B1	B2	H	H1	H2	F	PACK DIMENSIONS			VOLUME	WEIGHT
										L	B	H	m ³	Kg
130	93	59	102,5	76,5	26	125,5	75	50,5	48	135	135	150	0,0027	2,5

MODEL	POWER SUPPLY 50 Hz	CENTRE-DISTANCE mm	UNIONS ON REQUEST		ELECTRICAL DATA						MINIMUM SUCTION PRESSURE
			STANDARDIZED	SPECIAL	SPEED	rpm	P1 MAX W	I _n A	CAPACITOR µF V _c		
VA 35/130 1/2"	1x230 V ~	130	-	-	3	2465	56	0,25	1,7	450	t° +90°C m.c.a. 1,5
					2	1930	50	0,22			
					1	1150	35	0,16			

VA 35/180

SINGLE WITH UNIONS

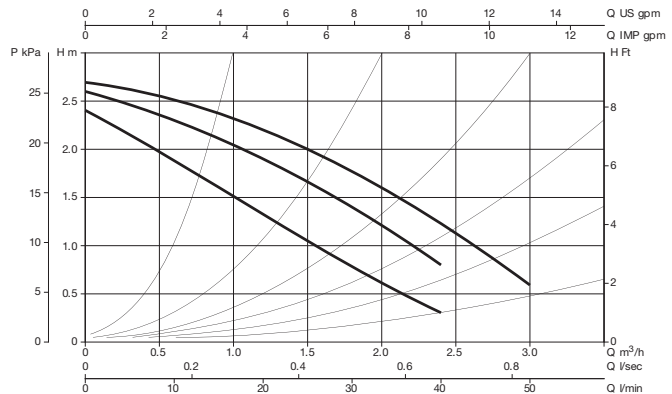
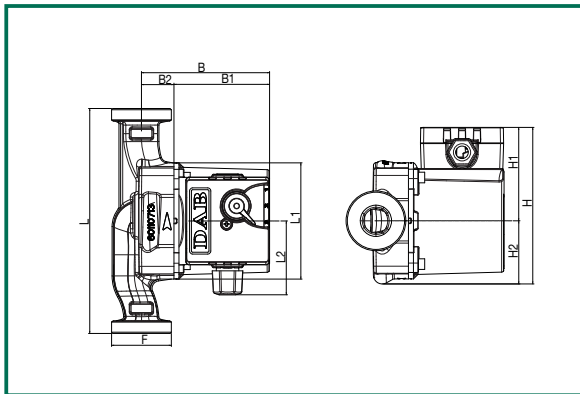
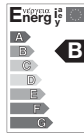

L	L1	L2	B	B1	B2	H	H1	H2	F	PACK DIMENSIONS			VOLUME	WEIGHT
										L	B	H	m ³	kg
180	93	59	102,5	76,5	26	125,5	75	50,5	48	130	190	150	0,0037	2,6

MODEL	POWER SUPPLY 50 Hz	CENTRE-DISTANCE mm	UNIONS ON REQUEST		ELECTRICAL DATA						MINIMUM SUCTION PRESSURE
			STANDARDIZED	SPECIAL	SPEED	rpm	P1 MAX W	I _n A	CAPACITOR µF V _c		
VA 35/180	1x230 V ~	180	1" F	3/4" F - 1 1/4" M	3	2465	56	0,25	1,7	450	t° +90°C m.c.a. 1,5
					2	1930	50	0,22			
					1	1150	35	0,16			

The performance curves are based on kinematic viscosity values = 1 mm²/s and density equivalent to 1000 kg/m³. Tolerance of curves to ISO 9906.

CIRCULATORS FOR HEATING AND AIR CONDITIONING SYSTEMS

Liquid temperature range: from -10°C to +110°C
 Maximum working pressure: 10 bar (1000 kPa)

VA 35/180X SINGLE WITH UNIONS

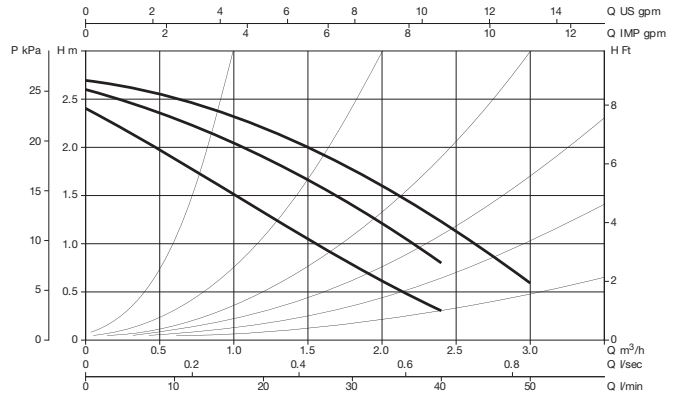
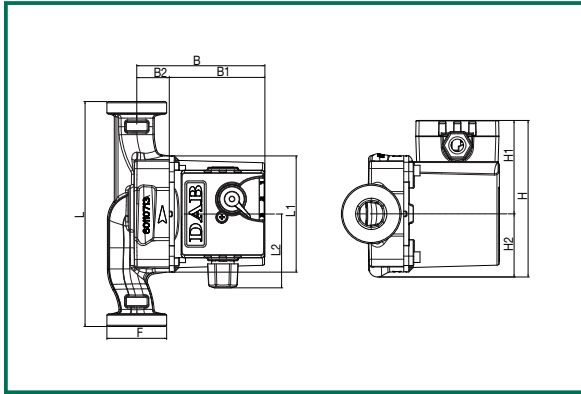
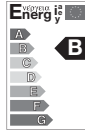

L	L1	L2	B	B1	B2	H	H1	H2	F	PACK DIMENSIONS			VOLUME m ³	WEIGHT kg
										L	B	H		
180	93	59	102,5	76,5	26	125,5	75	50,5	48	130	190	150	0,0037	2,6

MODEL	POWER SUPPLY 50 Hz	CENTRE-DISTANCE mm	UNIONS ON REQUEST	ELECTRICAL DATA						MINIMUM SUCTION PRESSURE
				SPEED	rpm	P1 MAX W	In A	CAPACITOR µF Vc		
VA 35/180X	1x230 V ~	180	1 1/4" F	3	2465	56	0,25	1,7	450	t° +90°C m.c.a. 1,5
				2	1930	50	0,22			
				1	1150	35	0,16			

VB 35/120 SINGLE WITH OVAL FLANGES

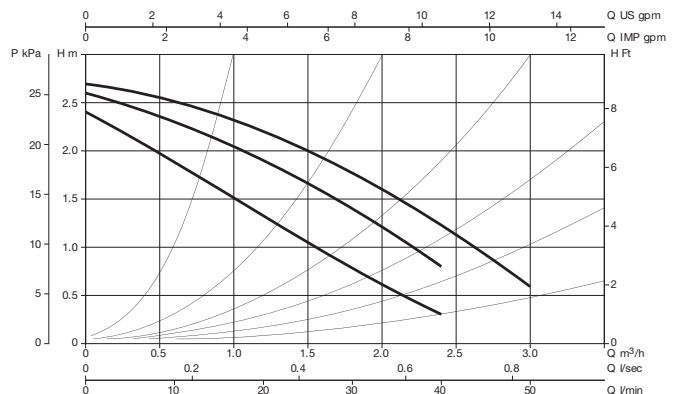
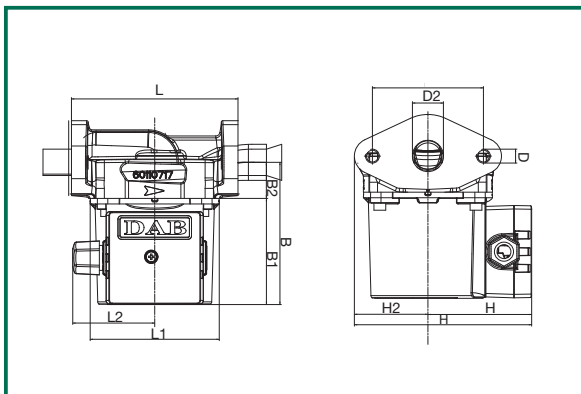
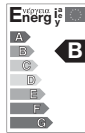

L	L1	L2	B	B1	B2	H	H1	H2	D2	D1	I	PACK DIMENSIONS			VOLUME m ³	WEIGHT Kg
												L	B	H		
120	98	60	104	78	26	124	75	49	25	M10	78	135	135	150	0,0027	2,7

MODEL	POWER SUPPLY 50 Hz	CENTRE-DISTANCE mm	UNIONS ON REQUEST		ELECTRICAL DATA						MINIMUM SUCTION PRESSURE
			STANDARDIZED	SPECIAL	SPEED	rpm	P1 MAX W	In A	CAPACITOR µF Vc		
VB 35/120	1x230 V ~	120	DN 25	DN 20 DN 32	3	2465	56	0,25	1,7	450	t° +90°C m.c.a. 1,5
					2	1930	50	0,22			
					1	1150	35	0,16			

The performance curves are based on kinematic viscosity values = 1 mm²/s and density equivalent to 1000 kg/m³. Tolerance of curves to ISO 9906.

CIRCULATORS FOR HEATING AND AIR CONDITIONING SYSTEMS

Liquid temperature range: from -10°C to +110°C
 Maximum working pressure: 10 bar (1000 kPa)

VA 55/130 SINGLE WITH UNIONS

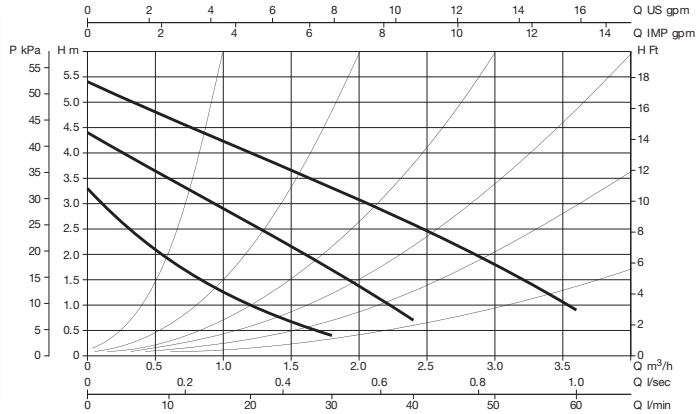
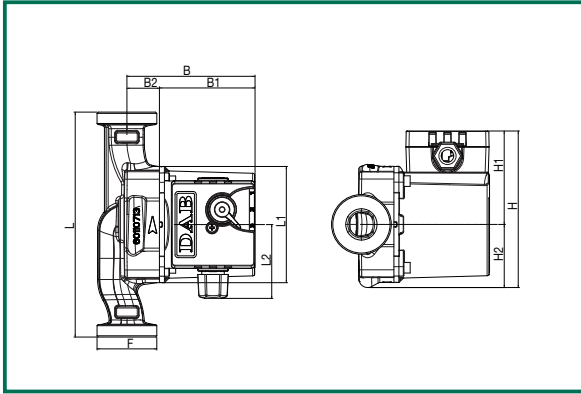
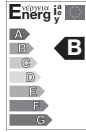

L	L1	L2	B	B1	B2	H	H1	H2	F	PACK DIMENSIONS			VOLUME m ³	WEIGHT kg
										L	B	H		
130	93	59	102,5	76,5	26	125,5	75	50,5	48	135	135	150	0,0027	2,5

MODEL	POWER SUPPLY 50 Hz	CENTRE-DISTANCE mm	UNIONS ON REQUEST		ELECTRICAL DATA						MINIMUM SUCTION PRESSURE
			STANDARDIZED	SPECIAL	SPEED	rpm	P1 MAX W	In A	CAPACITOR µF Vc		
VA 55/130	1x230 V ~	130	1" F	3/4" F - 1 1/4" M	3	2400	70	0,3	1,7	450	t° +90°C m.c.a. 1,5
					2	1600	58	0,26			
					1	930	36	0,17			

VA 55/130 - 1/2"

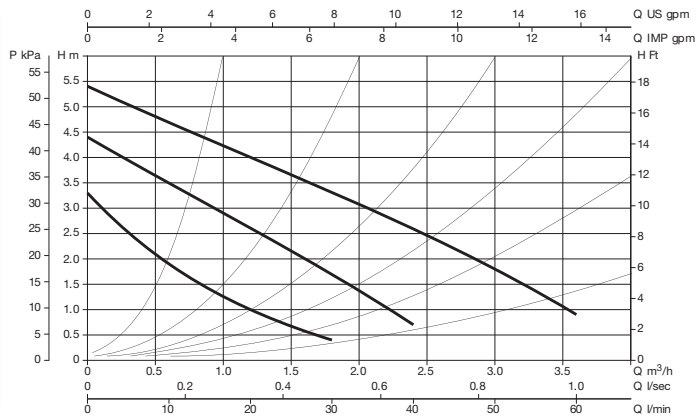
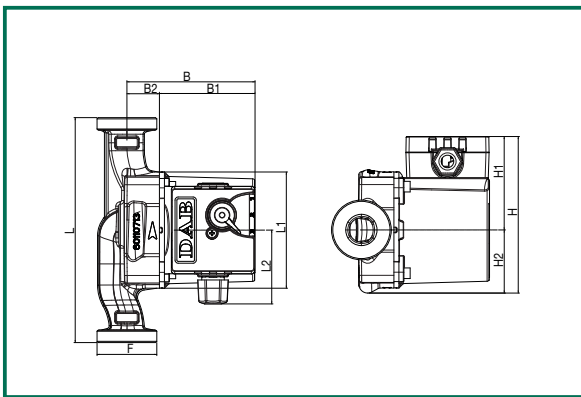
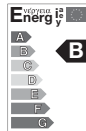

L	L1	L2	B	B1	B2	H	H1	H2	F	PACK DIMENSIONS			VOLUME m ³	WEIGHT kg
										L	B	H		
130	93	59	102,5	76,5	26	125,5	75	50,5	48	135	135	150	0,0027	2,5

MODEL	POWER SUPPLY 50 Hz	CENTRE-DISTANCE mm	UNIONS ON REQUEST		ELECTRICAL DATA						MINIMUM SUCTION PRESSURE
			STANDARDIZED	SPECIAL	SPEED	rpm	P1 MAX W	In A	CAPACITOR µF Vc		
VA 55/130 - 1/2"	1x230 V ~	130	-	-	3	2400	70	0,3	1,7	450	t° +90°C m.c.a. 1,5
					2	1600	58	0,26			
					1	930	36	0,17			

The performance curves are based on kinematic viscosity values = 1 mm²/s and density equivalent to 1000 kg/m³. Tolerance of curves to ISO 9906.

CIRCULATORS FOR HEATING AND AIR CONDITIONING SYSTEMS

Liquid temperature range: from -10°C to +110°C
 Maximum working pressure: 10 bar (1000 kPa)

VA 55/180 SINGLE WITH UNIONS

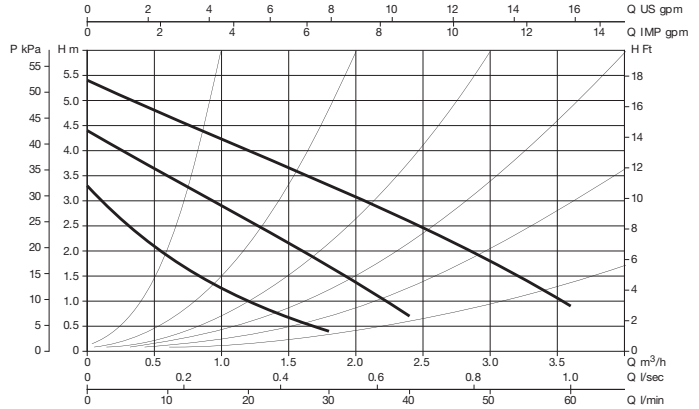
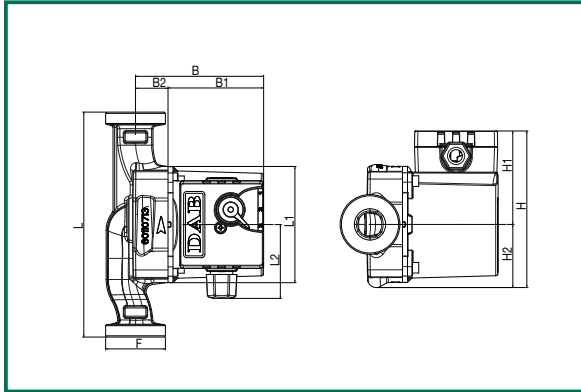
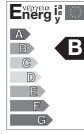

L	L1	L2	B	B1	B2	H	H1	H2	F	PACK DIMENSIONS			VOLUME m ³	WEIGHT kg
										L	B	H		
180	93	59	102,5	76,5	26	125,5	75	50,5	48	130	190	150	0,0037	2,6

MODEL	POWER SUPPLY 50 Hz	CENTRE-DISTANCE mm	UNIONS ON REQUEST		ELECTRICAL DATA						MINIMUM SUCTION PRESSURE	
			STANDARDIZED	SPECIAL	SPEED	rpm	P1 MAX W	I _n A	CAPACITOR μF V _c			
VA 55/180	1x230 V ~	180	1" F	3/4" F - 1 1/4" M	3	2400	70	0,3	1,7		450	t° +90°C m.c.a. 1,5
					2	1600	58	0,26				
					1	930	36	0,17				

VA 55/180X SINGLE WITH UNIONS

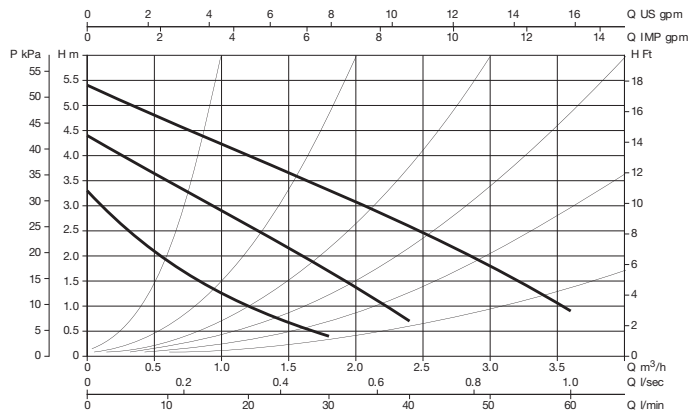
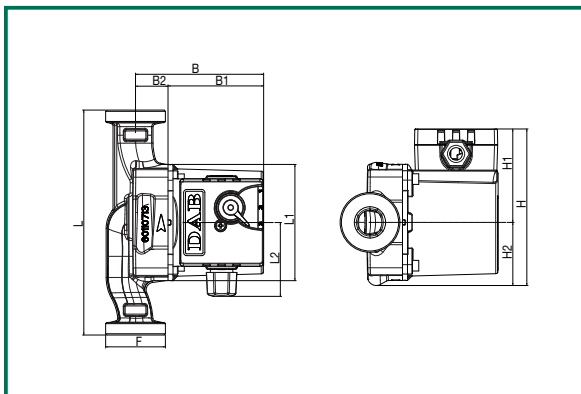
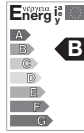

L	L1	L2	B	B1	B2	H	H1	H2	F	PACK DIMENSIONS			VOLUME m ³	WEIGHT kg
										L	B	H		
180	93	59	102,5	76,5	26	125,5	75	50,5	48	130	190	150	0,0037	2,6

MODEL	POWER SUPPLY 50 Hz	CENTRE-DISTANCE mm	UNIONS ON REQUEST	ELECTRICAL DATA						MINIMUM SUCTION PRESSURE	
				SPEED	rpm	P1 MAX W	I _n A	CAPACITOR μF V _c			
VA 55/180X	1x230 V ~	180	1 1/4" F	3	2400	70	0,3	1,7		450	t° +90°C m.c.a. 1,5
				2	1600	58	0,26				
				1	930	36	0,17				

The performance curves are based on kinematic viscosity values = 1 mm²/s and density equivalent to 1000 kg/m³. Tolerance of curves to ISO 9906.

CIRCULATORS FOR HEATING AND AIR CONDITIONING SYSTEMS

Liquid temperature range: from -10°C to +110°C
 Maximum working pressure: 10 bar (1000 kPa)

VB 55/120 SINGLE WITH OVAL FLANGES

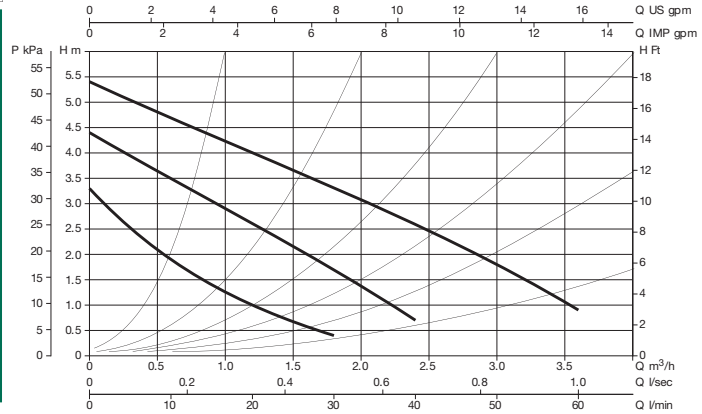
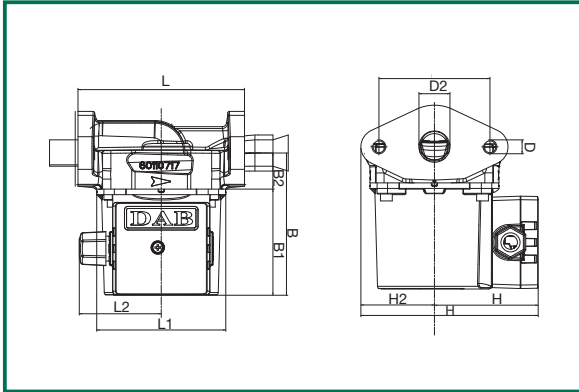
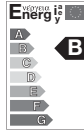

L	L1	L2	B	B1	B2	H	H1	H2	D2	D1	I	PACK DIMENSIONS			VOLUME	WEIGHT
												L	B	H	m ³	Kg
120	98	60	104	78	26	124	75	49	25	M10	80	135	135	150	0,0027	2,7

MODEL	POWER SUPPLY 50 Hz	CENTRE-DISTANCE mm	UNIONS ON REQUEST		ELECTRICAL DATA						MINIMUM SUCTION PRESSURE
			STANDARDIZED	SPECIAL	SPEED	rpm	P1 MAX W	In A	CAPACITOR µF Vc		
VB 55/120	1x230 V ~	120	DN 25	DN 20 DN 32	3	2400	70	0,3	1,7	450	t° +90°C m.c.a. 1,5
					2	1600	58	0,26			
					1	930	36	0,17			

VD 55/220.32 TWIN FLANGED

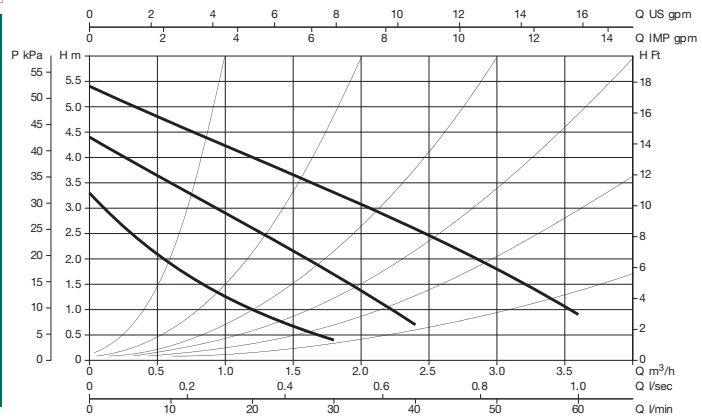
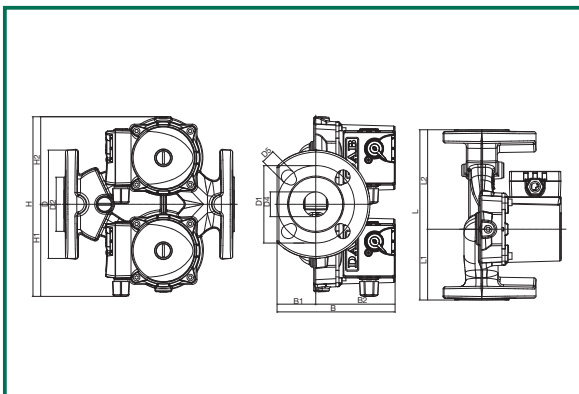
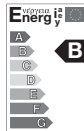

L	L1	L2	B	B1	B2	D	D1 PN6/PN10	D2	D4	D5 PN6/PN10	H	H1	H2	PACK DIMENSIONS			VOLUME	WEIGHT
														B	L	H	m ³	Kg
220	91,5	128,5	150	50	100	140	90 100	70	32	14 18	230	115	115	160	253	238	0,0096	8,2

MODEL	POWER SUPPLY 50 Hz	CENTRE-DISTANCE mm	UNIONS ON REQUEST	ELECTRICAL DATA*						MINIMUM SUCTION PRESSURE
				SPEED	rpm	P1 MAX W	In A	CAPACITOR µF Vc		
VD 55/220.32	1x230 V ~	220	DN 32 / PN 6 / PN 10	3	2400	70	0,3	1,7	450	t° +90°C m.c.a. 1,5
				2	1600	58	0,26			
				1	930	36	0,17			

*Electrical and hydraulic data refer to operation of just one motor.

The performance curves are based on kinematic viscosity values = 1 mm²/s and density equivalent to 1000 kg/m³. Tolerance of curves to ISO 9906.

CIRCULATORS FOR HEATING AND AIR CONDITIONING SYSTEMS

Liquid temperature range: from -10°C to +110°C
 Maximum working pressure: 10 bar (1000 kPa)

VA 65/130 SINGLE WITH UNIONS

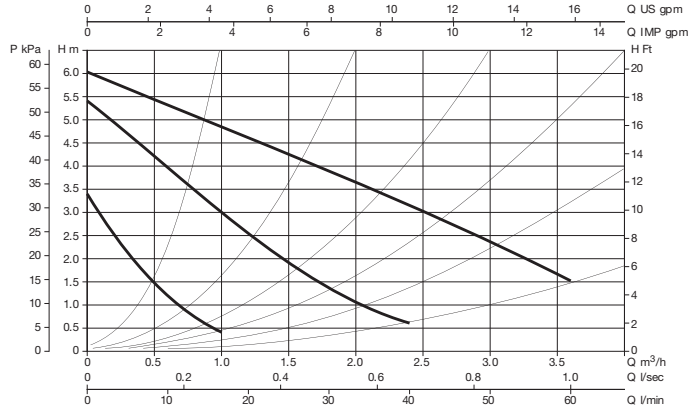
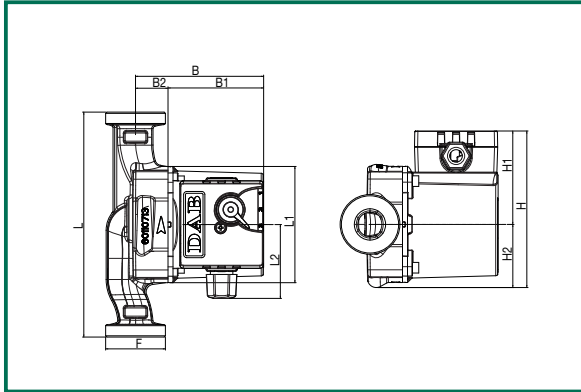

L	L1	L2	B	B1	B2	H	H1	H2	F	PACK DIMENSIONS			VOLUME m ³	WEIGHT kg
										L	B	H		
130	93	59	102,5	76,5	26	125,5	75	50,5	48	135	135	150	0,0027	2,5

MODEL	POWER SUPPLY 50 Hz	CENTRE-DISTANCE mm	UNIONS ON REQUEST		ELECTRICAL DATA						MINIMUM SUCTION PRESSURE
			STANDARDIZED	SPECIAL	SPEED	rpm	P1 MAX W	In A	CAPACITOR μF Vc		
VA 65/130	1x230 V ~	130	1" F	3/4" F - 1 1/4" M	3	2310	78	0,34	2	450	t° +90°C m.c.a. 2,5
					2	1532	59	0,26			
					1	880	37	0,17			

VA 65/130 1/2" SINGLE WITH UNIONS

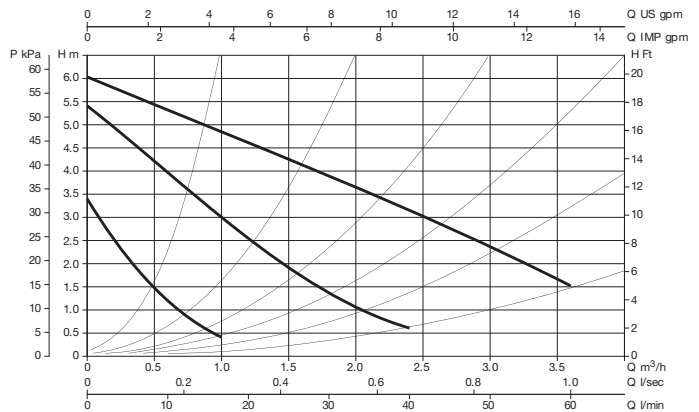
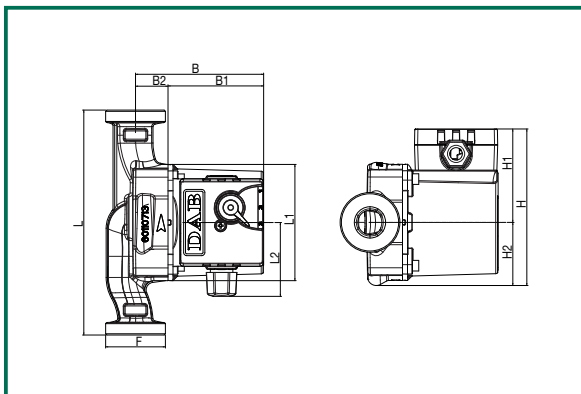
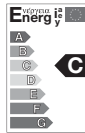

L	L1	L2	B	B1	B2	H	H1	H2	F	PACK DIMENSIONS			VOLUME m ³	WEIGHT kg
										L	B	H		
130	93	59	102,5	76,5	26	125,5	75	50,5	48	135	135	150	0,0027	2,5

MODEL	POWER SUPPLY 50 Hz	CENTRE-DISTANCE mm	UNIONS ON REQUEST		ELECTRICAL DATA						MINIMUM SUCTION PRESSURE
			STANDARDIZED	SPECIAL	SPEED	rpm	P1 MAX W	In A	CAPACITOR μF Vc		
VA 65/130 1/2"	1x230 V ~	130	-	-	3	2310	78	0,34	2	450	t° +90°C m.c.a. 2,5
					2	1532	59	0,26			
					1	880	37	0,17			

The performance curves are based on kinematic viscosity values = 1 mm²/s and density equivalent to 1000 kg/m³. Tolerance of curves to ISO 9906.

CIRCULATORS FOR HEATING AND AIR CONDITIONING SYSTEMS

Liquid temperature range: from -10°C to +110°C
 Maximum working pressure: 10 bar (1000 kPa)

VA 65/180 SINGLE WITH UNIONS

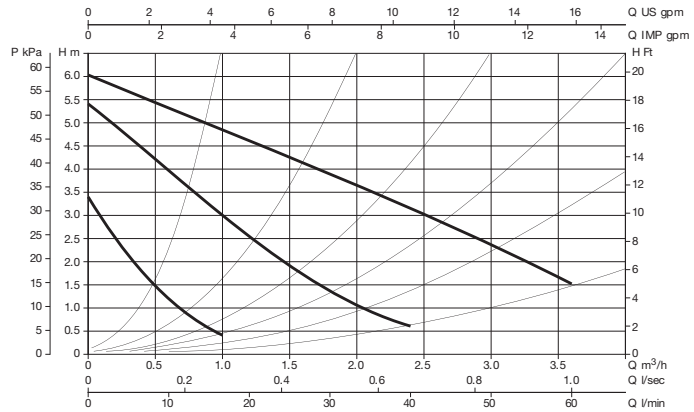
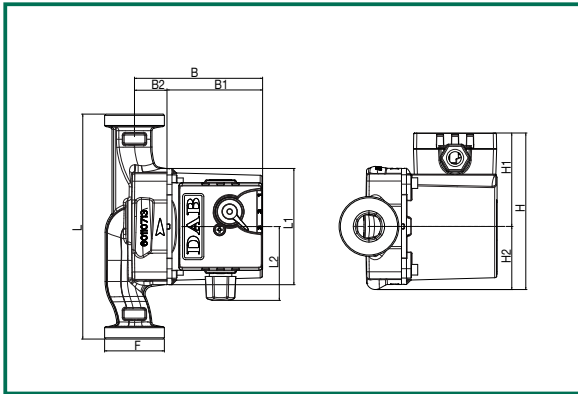
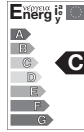

L	L1	L2	B	B1	B2	H	H1	H2	F	PACK DIMENSIONS			VOLUME m ³	WEIGHT kg
										L	B	H		
180	93	59	102,5	76,5	26	125,5	75	50,5	48	130	190	150	0,0037	2,6

MODEL	POWER SUPPLY 50 Hz	CENTRE-DISTANCE mm	UNIONS ON REQUEST		ELECTRICAL DATA						MINIMUM SUCTION PRESSURE
			STANDARDIZED	SPECIAL	SPEED	rpm	P1 MAX W	I _n A	CAPACITOR µF V _c		
VA 65/180	1x230 V ~	180	1" F	3/4" F - 1 1/4" M	3	2310	78	0,34	2	450	t° +90°C m.c.a. 2,5
					2	1532	59	0,26			
					1	880	37	0,17			

VA 65/180X SINGLE WITH UNIONS

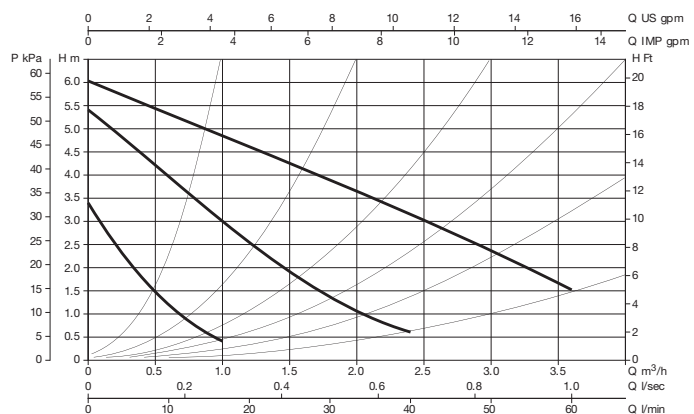
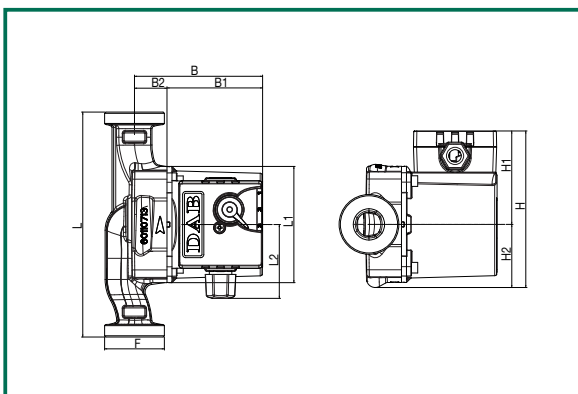
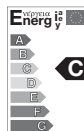

L	L1	L2	B	B1	B2	H	H1	H2	F	PACK DIMENSIONS			VOLUME m ³	WEIGHT kg
										L	B	H		
180	93	59	102,5	76,5	26	125,5	75	50,5	48	130	190	150	0,0037	2,6

MODEL	POWER SUPPLY 50 Hz	CENTRE-DISTANCE mm	UNIONS ON REQUEST	ELECTRICAL DATA						MINIMUM SUCTION PRESSURE
				SPEED	rpm	P1 MAX W	I _n A	CAPACITOR µF V _c		
VA 65/180X	1x230 V ~	180	1 1/4" F	3	2310	78	0,34	2	450	t° +90°C m.c.a. 2,5
				2	1532	59	0,26			
				1	880	37	0,17			

The performance curves are based on kinematic viscosity values = 1 mm²/s and density equivalent to 1000 kg/m³. Tolerance of curves to ISO 9906.

CIRCULATORS FOR HEATING AND AIR CONDITIONING SYSTEMS

Liquid temperature range: from -10°C to +110°C
 Maximum working pressure: 10 bar (1000 kPa)

VB 65/120 SINGLE WITH OVAL FLANGES

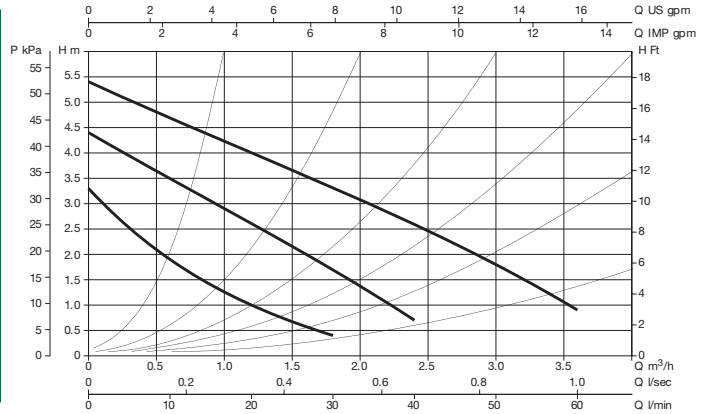
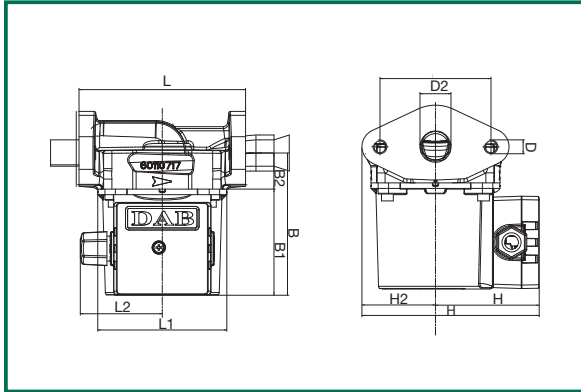
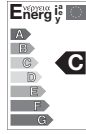

L	L1	L2	B	B1	B2	D2	D1	I	H	H1	H2	PACK DIMENSIONS			VOLUME	WEIGHT
												L	B	H	m ³	Kg
120	98	60	104	78	26	26	M10	80	124	75	49	135	135	150	0,0027	2,7

MODEL	POWER SUPPLY 50 Hz	CENTRE-DISTANCE mm	UNIONS ON REQUEST		ELECTRICAL DATA						MINIMUM SUCTION PRESSURE	
			STANDARDIZED	SPECIAL	SPEED	rpm	P1 MAX W	In A	CAPACITOR			
										μF	Vc	
VB 65/120	1x230 V ~	120	DN 25	DN 20 DN 32	3	2310	78	0,34	2	450		t° +90°C m.c.a. 2,5
					2	1532	59	0,26				
					1	880	37	0,17				

VD 65/220.32 TWIN FLANGED

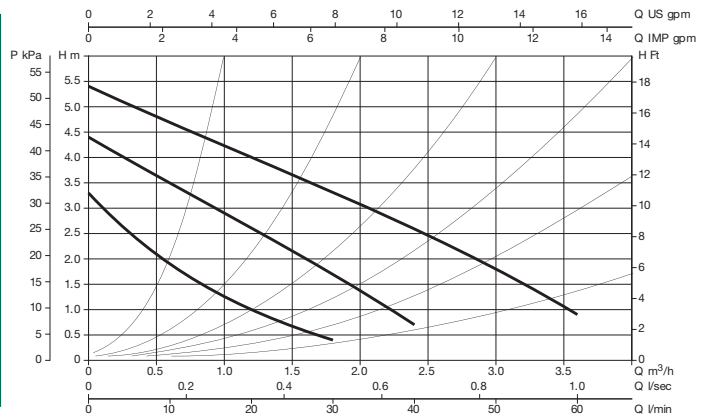
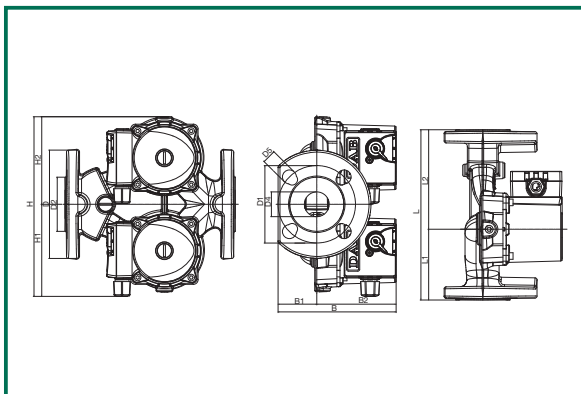
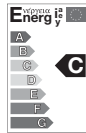

L	L1	L2	B	B1	B2	D	D1 PN6/PN10	D2	D4	D5 PN6/PN10	H	H1	H2	PACK DIMENSIONS			VOLUME	WEIGHT
														B	L	H	m ³	Kg
220	91,5	128,5	150	50	100	140	90 100	70	31	14 18	230	115	115	160	253	238	0,0096	8,2

MODEL	POWER SUPPLY 50 Hz	CENTRE-DISTANCE mm	UNIONS ON REQUEST	ELECTRICAL DATA*						MINIMUM SUCTION PRESSURE
				SPEED	rpm	P1 MAX W	In A	CAPACITOR		
								μF	Vc	
VD 65/220.32	1x230 V ~	220	DN 32 / PN 6 / PN 10	3	2310	78	0,34	2	450	t° +90°C m.c.a. 2,5
				2	1532	59	0,26			
				1	880	37	0,17			

*Electrical and hydraulic data refer to operation of just one motor.